

# Dimensions for Type DZ

## Size 1

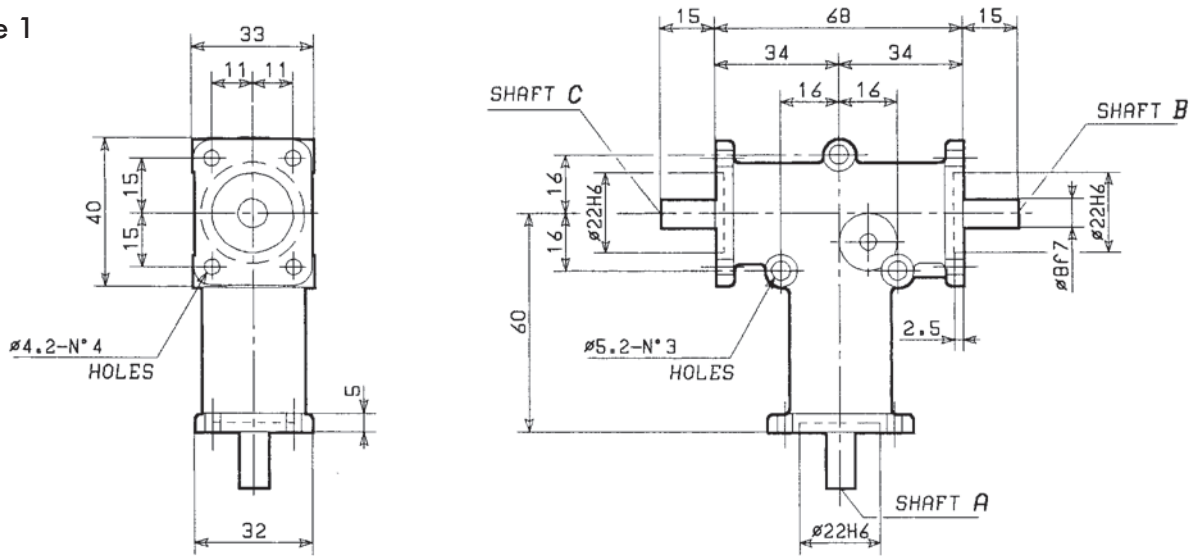

Size 1	Ratio	Input	Output	Part Number
	1:1	A	B	DZ10S 3FAB
	2:1		B	DZ12S 3FAB
	1:1		B & C	DZ11 3FABC
	2:1		B & C	DZ13 3FABC

## Size 2

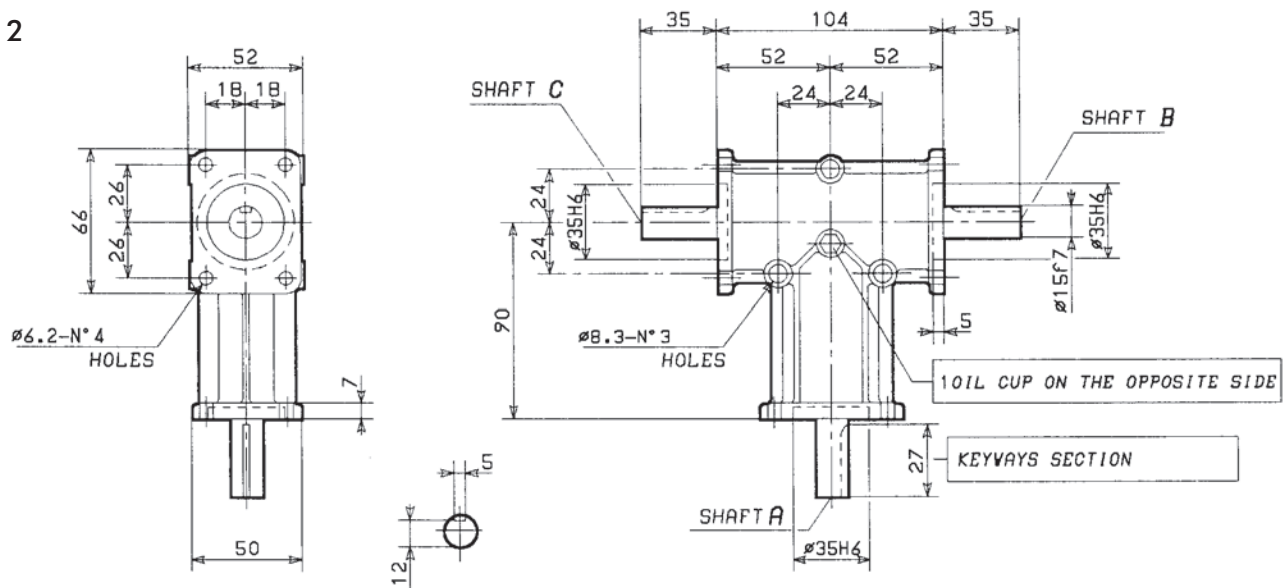

Size 2	Ratio	Input	Output	Part Number
	1:1	A	B	DZ20S 3FAB
	2:1		B	DZ22S 3FAB
	1:1		B & C	DZ21 3FABC
	2:1		B & C	DZ23 3FABC

All dimensions in mm.  
All dimensions are subject to change without notice.

# Dimensions for Type DZ

## Size 3

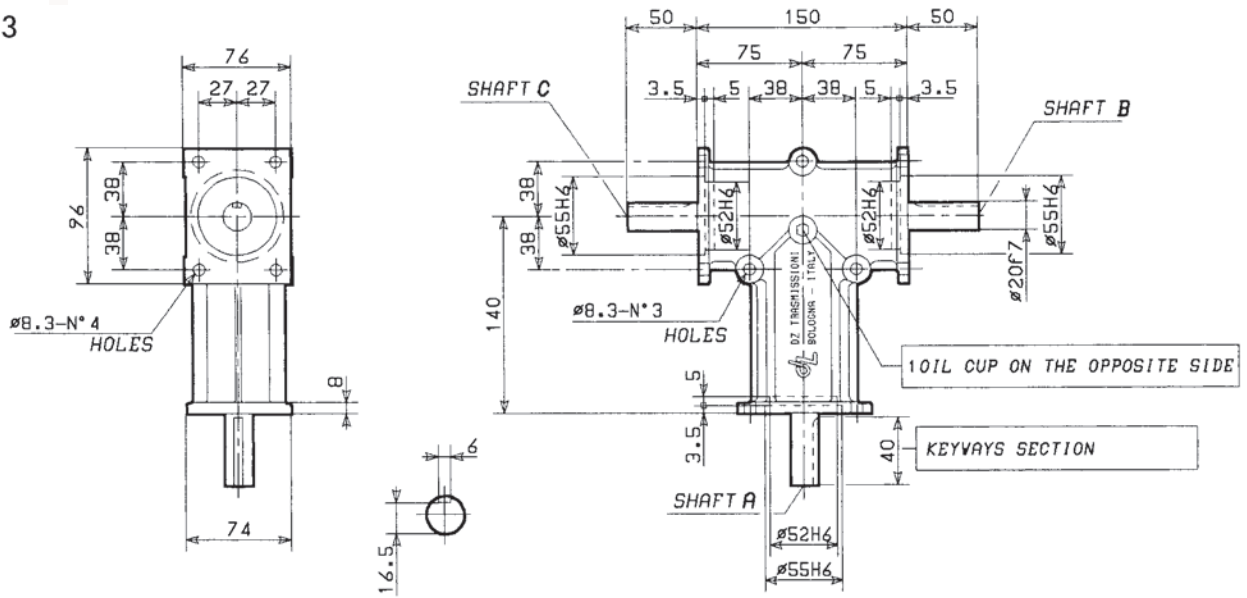

Size 3	Ratio	Input	Output	Part Number
	1:1	A	B	DZ30S 3FAB
	2:1		B	DZ32S 3FAB
	1:1		B & C	DZ31 3FABC
	2:1		B & C	DZ33 3FABC

## Size 4

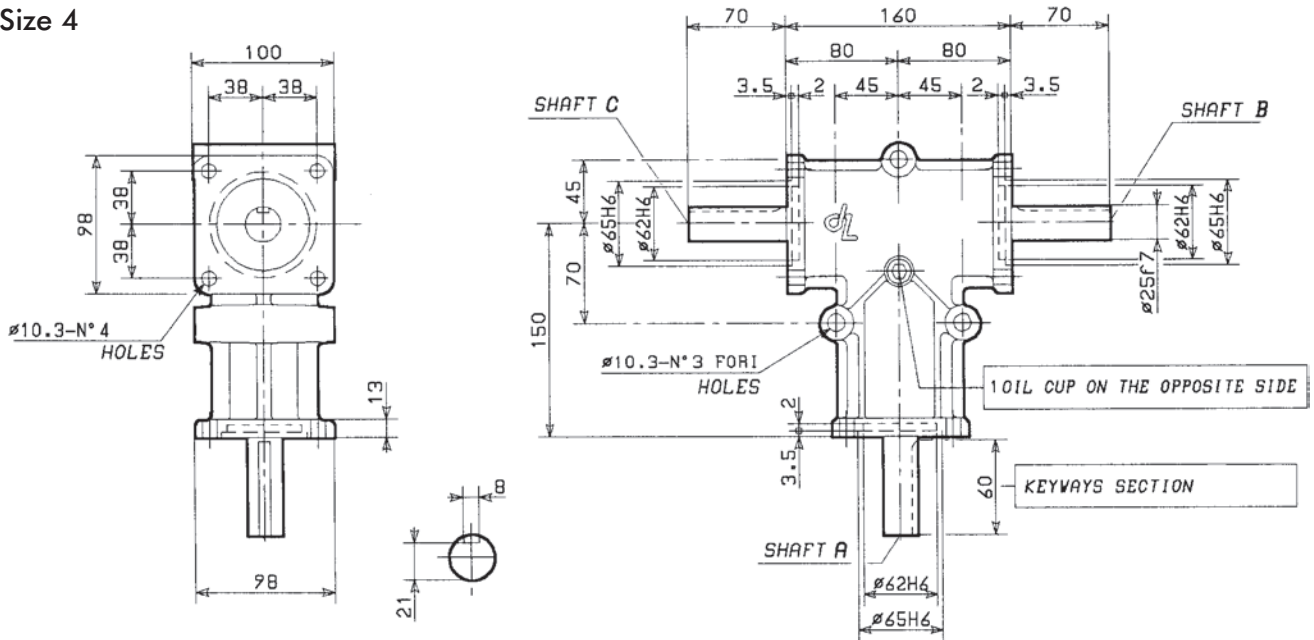

Size 4	Ratio	Input	Output	Part Number
	1:1	A	B	DZ40S 3FAB
	2:1		B	DZ42S 3FAB
	1:1		B & C	DZ41 3FABC
	2:1		B & C	DZ43 3FABC

All dimensions in mm.  
All dimensions are subject to change without notice.

# Dimensions for Type DZ & DZ Specials

Size 5

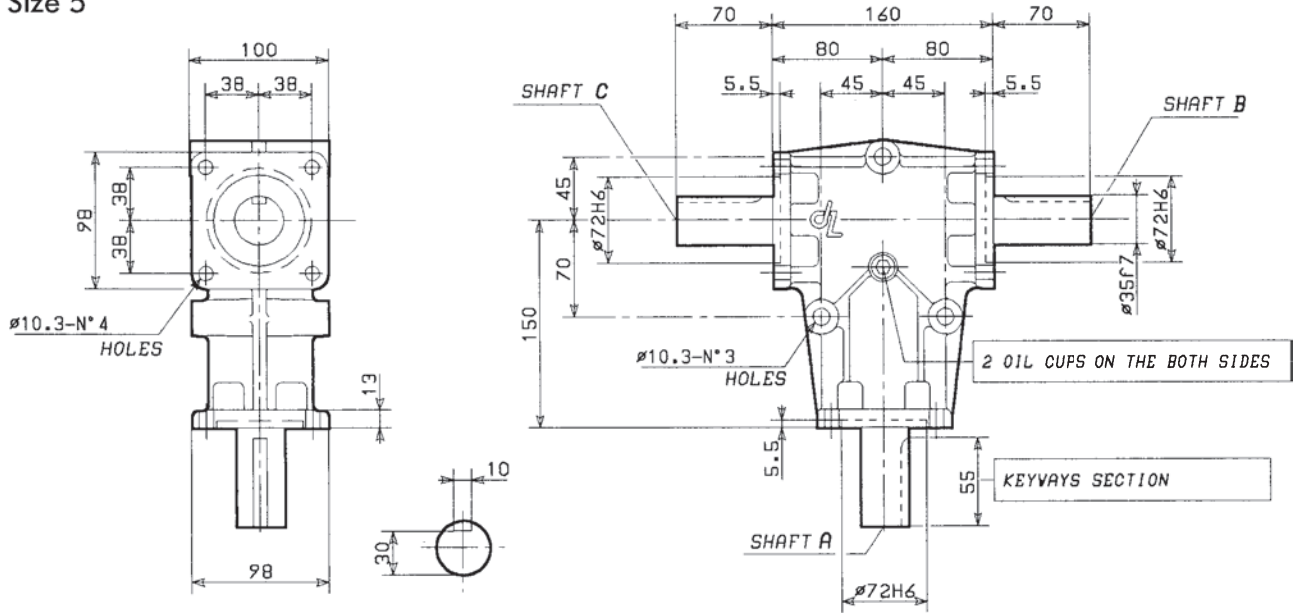

Size 5	Ratio	Input	Output	Part Number
	1:1	A	B	DZ50S 3FAB
	2:1		B	DZ52S 3FAB
	1:1		B & C	DZ51 3FABC
	2:1		B & C	DZ53 3FABC

## DZ Special

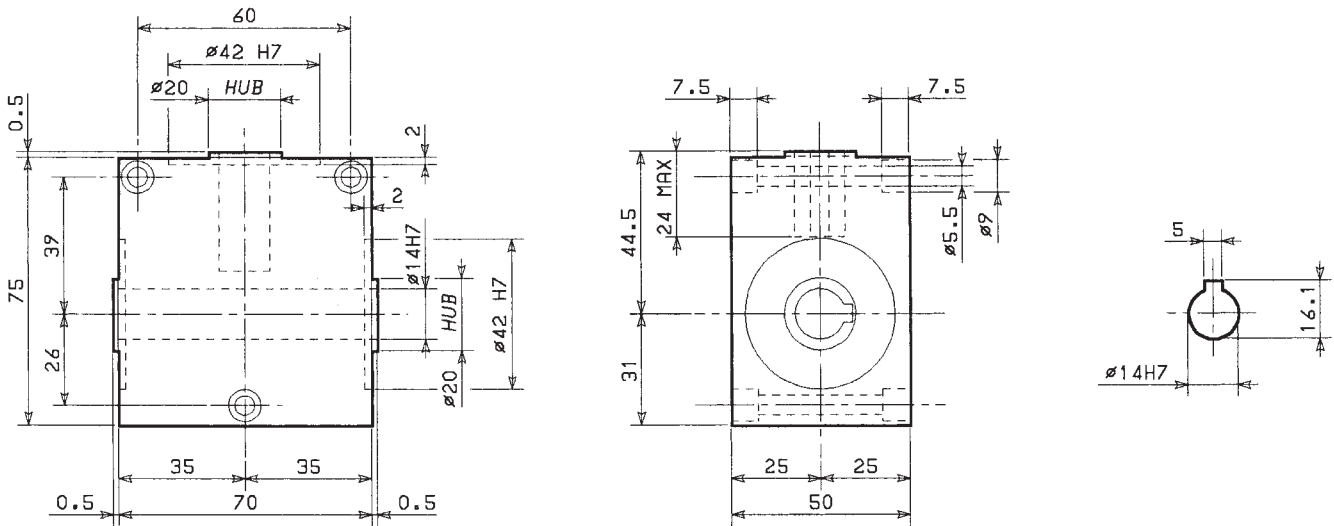

Special	Ratio	Input	Output	Part Number
	1:1	A	B & C	DZ50S-60

All dimensions in mm.  
All dimensions are subject to change without notice.



***Your partner in quality engineering products since 1986***

Thank you for viewing product information on TEA's range of engineering components.

Now please contact us at the nearest office to you for any further information, prices and availability:



**AUSTRALIA & New Zealand**  
**T.E.A. Transmissions Pty Ltd**  
Tahiti Road  
Tiaro Qld 4650  
Australia

Ph: 61-(0)7 4129 2533  
Fax: 61-(0)7 4129 2437  
Email: [sales@tea.net.au](mailto:sales@tea.net.au)  
[www.tea.net.au](http://www.tea.net.au)



**USA, South America & Canada**  
**T.E.A. Machine Components Inc.**  
2281-F Dabney Road  
Richmond Virginia 23230  
USA

Ph: 1-804-342-0004  
Fax: 1-804-342-0006  
Email: [sales@teausa.net](mailto:sales@teausa.net)  
[www.teausa.net](http://www.teausa.net)

**You are assured of prompt and efficient service at all time.**