

WINKEL-Rollen | WINKEL Bearings



Justierbare WINKEL-Rolleneinheit Typ JT

Vorteile:

- Radial und axial stufenlos von außen einstellbar
- Höhere radiale und axiale Präzision
- Schmutzunempfindlich
- Für Einsatz von Verfahrgeschwindigkeiten bis 2 m/sec

CAD Download in 2D/3D unter www.winkel.de

Adjustable WINKEL Bearing Unit Type JT

Advantages:

- Clearance radial and axial steplessly adjustable by thread bolts
- Higher radial and axial precision
- Higher dirt resistance
- For high speed application up to 2 m/sec

CAD download in 2D/3D at www.winkel.de

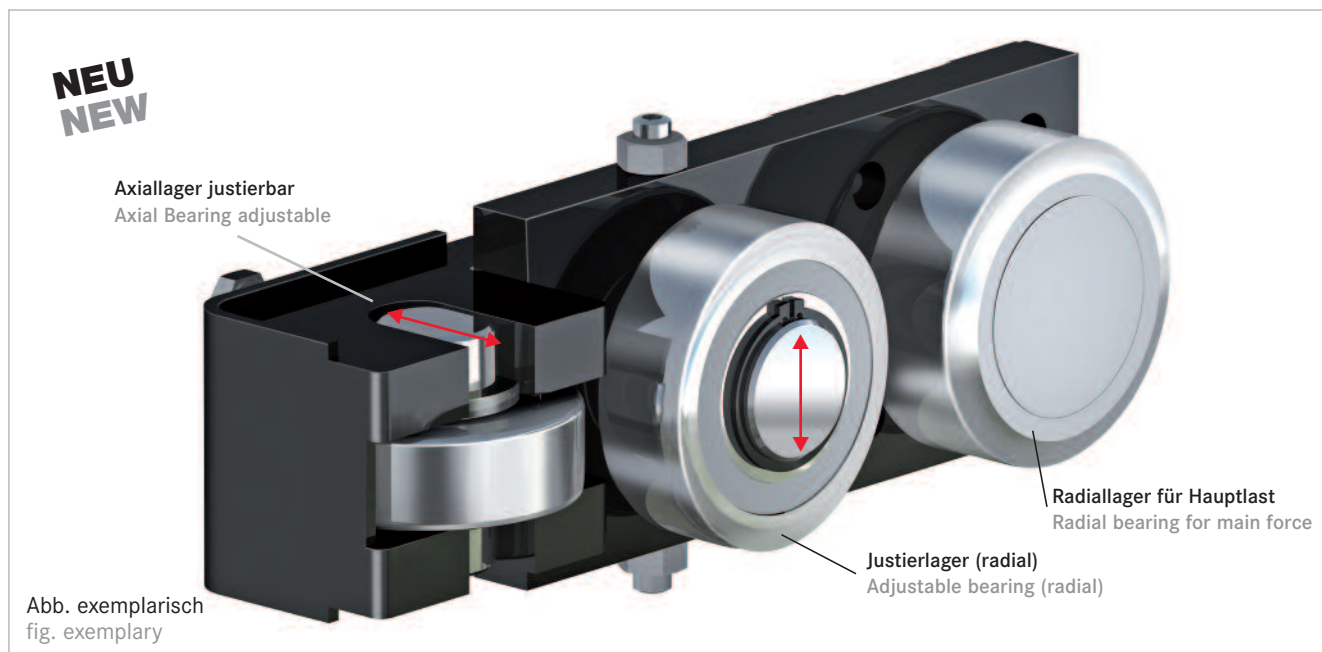

Einbau/Einstellung

- Die Einheit wird über die Flanschplatte angeschraubt
- Die Position der Justierlager muss an der entgegengesetzten Seite der Last sein. Die Hauptlast soll auf das Radiallager eingeleitet werden
- Justierlager und Axiallager werden eingestellt und anschließend gekontert

Vorsicht: Es dürfen keine großen Anpresskräfte auf Axiallager und Justierlager kommen, sonst droht die Gefahr von hohen Vorspannkräften die zu Profilbeschädigungen führen können.

Tip: Lassen Sie ein Spiel von 0,05 - 0,1 mm zwischen den Axiallager und Justierlager und Profil.

Test: Der Führungswagen soll sich ohne große Laufwiderstände bewegen können.



Nachschmiersysteme für WINKEL-Rollen
Lubrication systems for WINKEL bearings
(Seite/page 142)

Assembly/Adjusting

- The unit will be assembled by the flange plate
- The position of the adjustable bearings must be at the opposite side of the load. The main forces should be on the radial bearing
- The axial and adjustable bearing will be adjusted and finally locked

Attention: Avoid high contact pressure to the axial and adjustable bearing. (Risk of profile wear out.)

Advice: Adjust the axial and adjustable bearing with a clearance of 0.05 to 0.1 mm to the profile.

Test: The carriage should run smoothly in the profile without resistance.

Typ Type	Artikel-Nr. Article no.	D -0.1 [mm]	F_R [kN]	F_A [kN]	C [kN]	C_0 [kN]	C_A [kN]	C_{0A} [kN]	Gewicht kg Weight kg	Profile Profiles
JT 2.055	200.210.301	70,1	12,40	4,2	45,5	51,0	14,3	9,7	4,50	1 NbV
JT 2.056	200.192.000	77,7	12,90	4,2	48,0	56,8	14,3	9,7	4,85	2 NbV
JT 2.058	200.210.303	88,4	22,40	7,4	68,0	72,0	19,0	12,0	8,16	3 NbV

C = Dyn. Tragzahl Radiallager (ISO 281/1), C_0 = Stat. Tragzahl Radiallager (ISO 76), (WINKEL-Rolle)

C_A = Dyn. Tragzahl Axiallager (ISO 281/1), C_{0A} = Stat. Tragzahl Axiallager (ISO 76), (WINKEL-Rolle)

F_R = Tragzahl Radiallager zulässige Belastung zwischen Rolle und Profil

F_A = Tragzahl Axiallager zulässige Belastung zwischen Rolle und Profil (WINKEL-Rolle)

WINKEL-Rollen | WINKEL Bearings

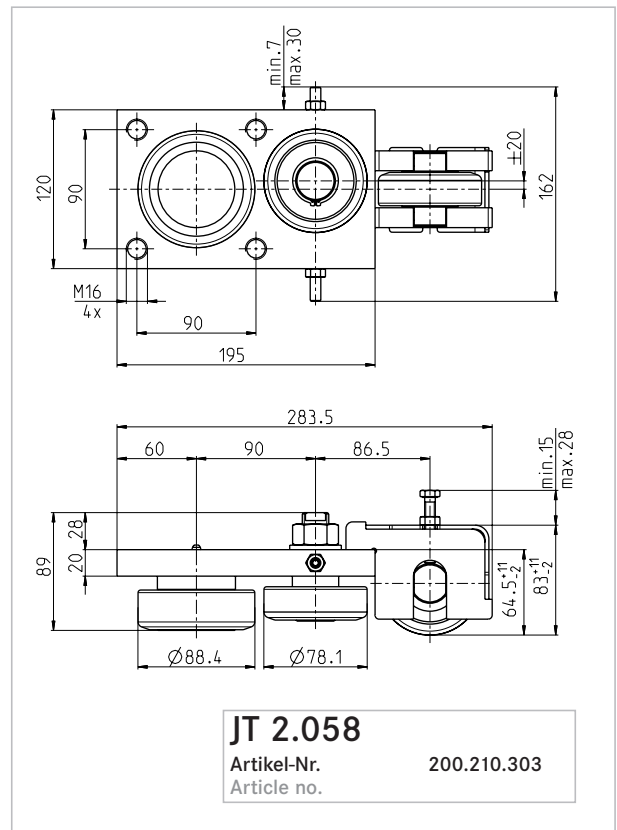
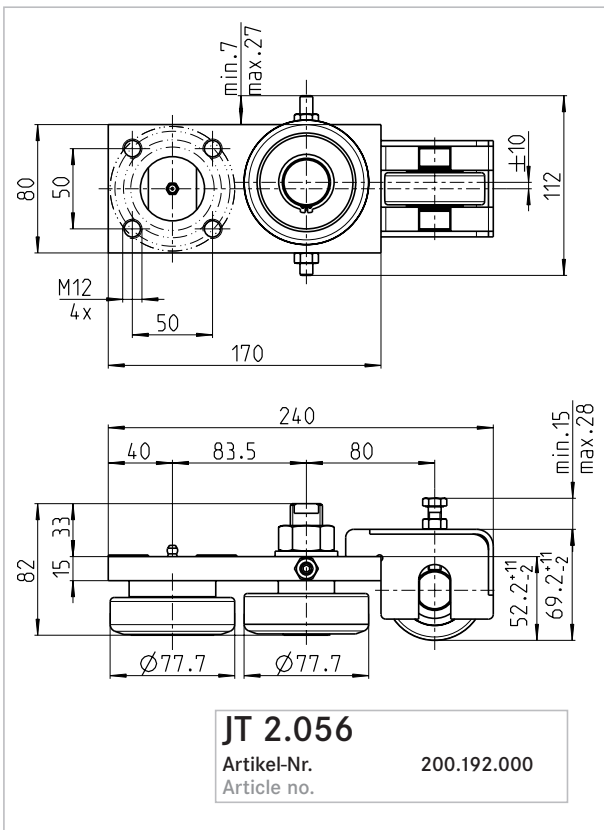
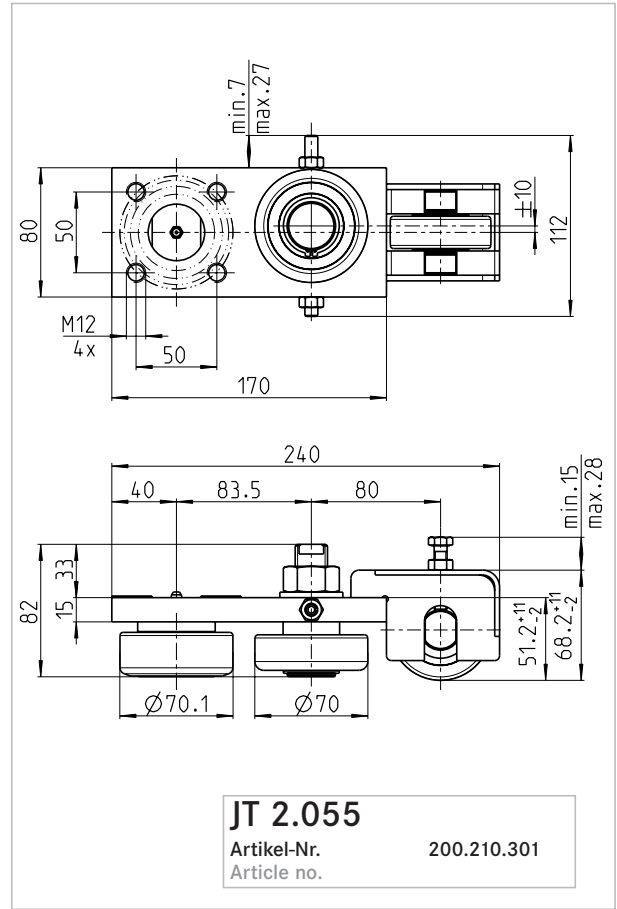
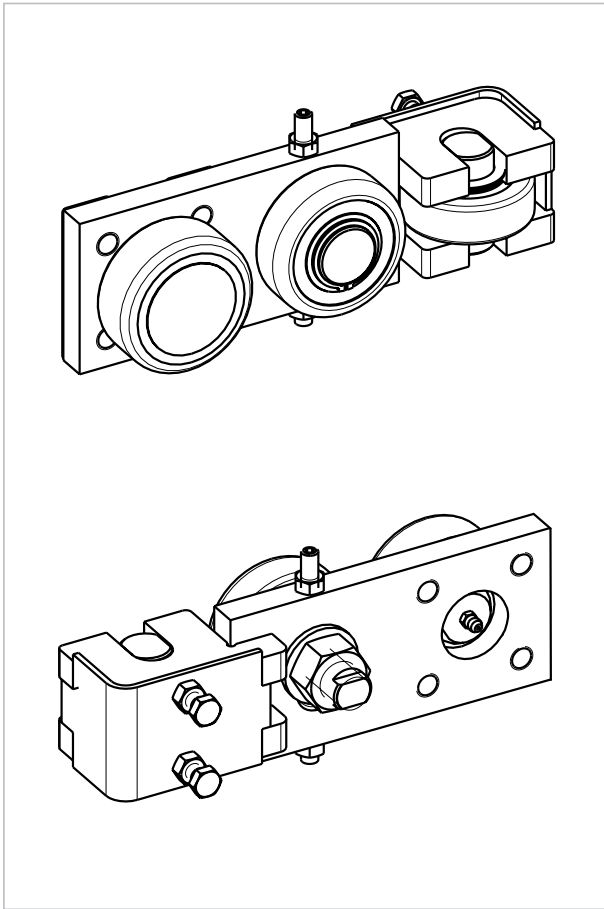

C = Dynamic load capacity radial bearing (ISO 281/1), C₀ = Static load capacity radial bearing (ISO 76), (WINKEL Bearing)
 C_A = Dynamic load capacity axial bearing (ISO 281/1), C_{0A} = Static load capacity axial bearing (ISO 76), (WINKEL Bearing)
 F_R = Load capacity radial bearing max. allowable force between bearing and profile, (WINKEL Bearing)
 F_A = Load capacity axial bearing max. allowable force between bearing and profile, (WINKEL Bearing)



**Thank you! For viewing product information on the T.E.A.
range of engineering components.**

T.E.A. Transmissions Pty Ltd

349 Tahiti Rd, Tiaro

Qld 4650 AUSTRALIA

Ph: 61-(0)7 4129 2533

Fax: 61-(0)7 4129 2437

sales@tea.net.au

www.tea.net.au



Your partner in quality engineering components since 1986